

Operating Instructions

VIVA Sugar Dispenser

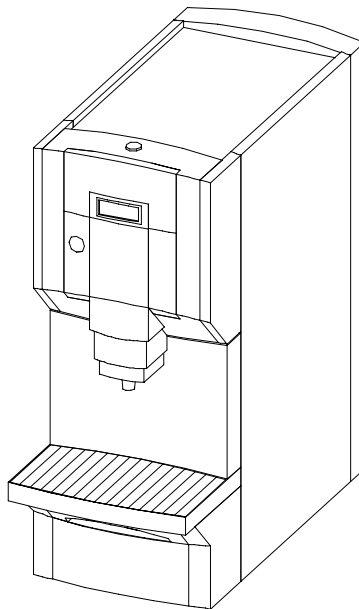

Dear customer,

Please read these Operating Instructions before using your "VIVA sugar dispenser".

The Operating Instructions contain important information for correct use of the unit and will help to ensure that it is used safely.

Always keep the Operating Instructions within easy reach!

VIVA sugar dispenser

- as a supplementary unit for the VIVA automatic coffee machine
- for automatically dispensing sugar

Legend:

 Activities to be undertaken

● Notes, function sequences

→ *Reference to further information*

1. Operational safety	2
2. Start-up	3
2.1 Filling the storage container	3
2.2 Switching on	5
2.3 Dispensing sugar	6
3. Switching off	6
4. Cleaning	6
4.1 Cleaning the sugar dispenser	7
4.2 Cleaning the storage container	9
4.3 Cleaning the housing	11
5. Troubleshooting	12
6. Technical data	13
7. Installation and connection	14
7.1 Installation	14
7.2 Electrical connection	15
8. Maintenance / Customer service / Rating plate	15
8.1 Maintenance notes	16

1. Operational safety

Operation

- The unit may only be operated
 - by duly instructed personnel and
 - for dispensing medium-fine sugar.
- The unit may only be operated out-of-doors when protected by a canopy roof and out of the wind. It must not be exposed to direct sunlight!
- Ensure that impurities do not enter the unit when filling and cleaning the storage container.
- Vents must not be covered. Do not allow any liquids to leak into the unit!
- Refer to chapter 5. "Troubleshooting" if any faults develop!

Disposal

- The various parts of the housing are made from recyclable plastics and are marked accordingly.

2. Start-up

- ☞ Clean the unit and particularly the storage container before using it for the first time (page 9).
- ☞ Prepare the unit for operation as described below.
- ☞ Plug mains connector into socket outlet.

2.1 Filling the storage container

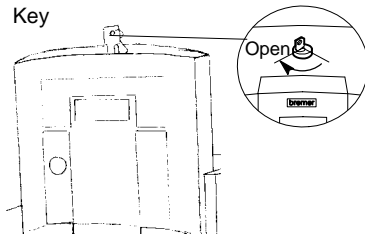

- ☞ Turn the key clockwise to unlock the cover.

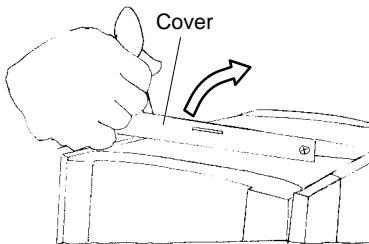

- ☞ Open the cover with the aid of a tea-spoon, for example.

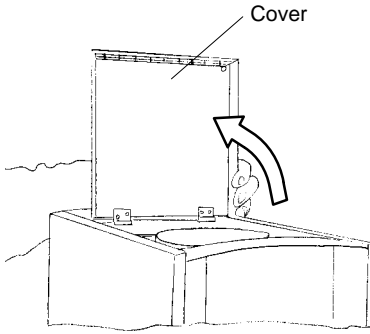

☞ Open the cover as far as possible.

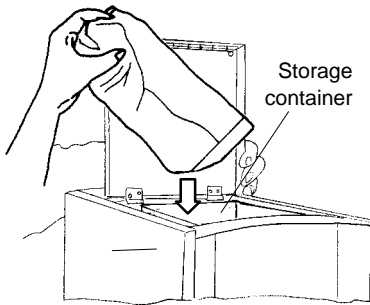

- ☞ Fill the storage container with medium-fine sugar.
- When filling the storage container, ensure that impurities are not entrained otherwise the unit may malfunction!

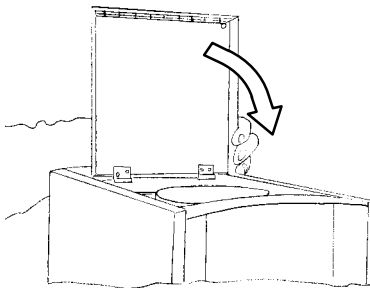

Closing the cover

☞ Fold the cover down and turn the key anticlockwise to lock it.

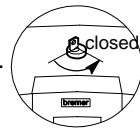

2.2 Switching on

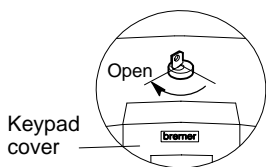

- ☞ Unlock the keypad cover with the key and open it.

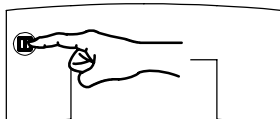

- ☞ Switch on the unit via the appliance switch .

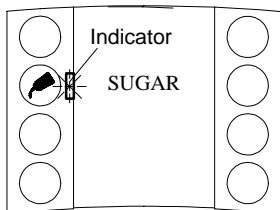

- The green power indicator lights up.

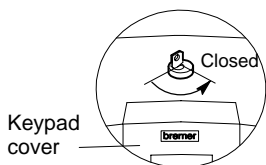



- ☞ Close and lock the keypad cover.

Ready for operation

- The VIVA Sugar Dispenser is ready for operation
 - when it is connected to the power supply and switched on and
 - when the storage container has been filled.

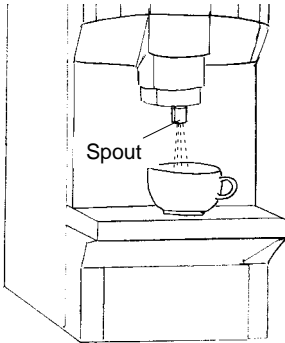
2.3 Dispensing sugar



- ☞ Place a cup on the drip tray under the spout.
- ☞ Press the product button .
- Sugar is dispensed until the product button is released.

3. Switching off

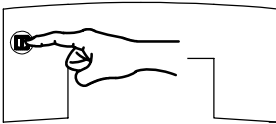

- ☞ Switch off the unit via the appliance switch .
- The LED in the product button goes out.
- ☞ Clean the unit after use as described in chapter 4.
- ☞ Unplug the mains connector.

4. Cleaning



- The VIVA Sugar Dispenser must be cleaned every day after closing.
- The unit must not be sprayed with water from a hose or high-pressure cleaner!
- Do not use any caustic or abrasive cleaning agents! Fat-dissolving agents or cleaning and care agents for stainless steel can be used to clean the unit. These products can be obtained from your customer service centre. Note the directions of the detergent manufacturers!

☞ Always switch off the unit via the appliance switch  before cleaning it.

4.1 Cleaning the sugar dispenser

Open the cover / front panel

☞ Open the cover as far as possible.

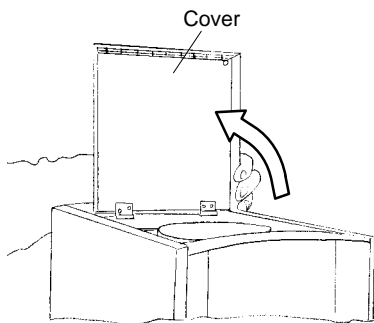

☞ Lift the front panel as far as possible.

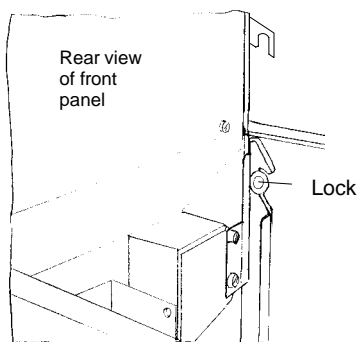
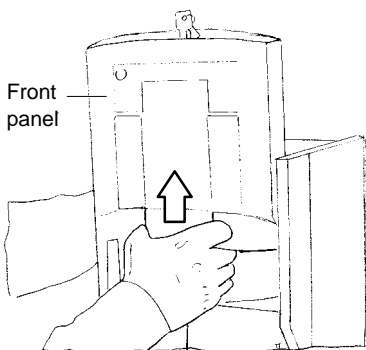

! Beware of crushed fingers!

Keep your fingers well clear of the locking area.

- ☞ Let the front panel engage in the lock.
- Examine the front panel to ensure that it has engaged correctly on both sides.

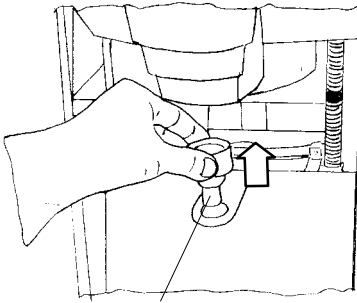

Dispensing funnel

Cleaning the dispensing funnel

- ☞ Lift out the dispensing funnel.
- Clean it daily with hot water and a washing-up brush.
- Towel it dry and
- refit it.

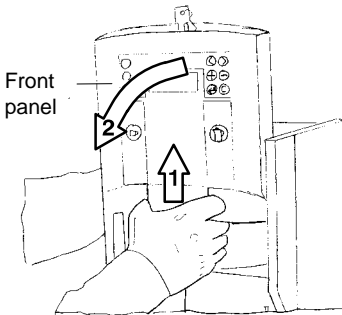

Front panel

Cleaning the dispensing chute

- ☞ Lift the front panel as far as possible (1) and fold it forwards (2).

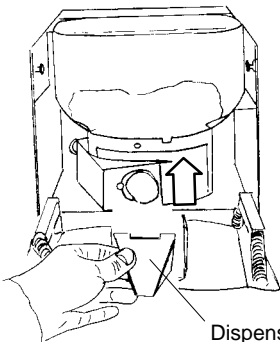

Dispensing chute

- ☞ Lift out the dispensing chute.
- ☞ Clean it daily with hot water and a washing-up brush.
- ☞ Towel it dry and
- ☞ refit it.

4.2 Cleaning the storage container

! **Avoid malfunctions!** Ensure that impurities are not entrained into the storage container.

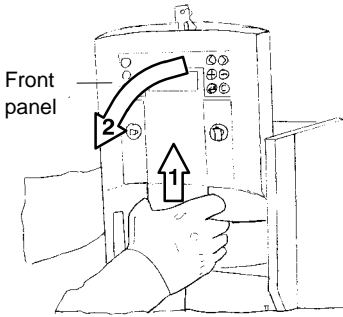

- ☞ Lift the front panel as far as possible (1) and fold it forwards (2).

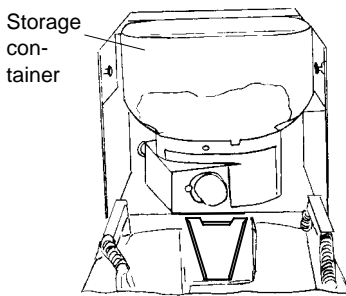

- ☞ Raise the front of the storage container with both hands, draw it forwards and pull it out of the unit. Place it on the table beside the unit.
- Do not immerse the storage container in water!
- ☞ The empty storage container must be cleaned
 - with a dry lintfree soft cloth and a brush
 - when the unit is switched off
 - once per month.

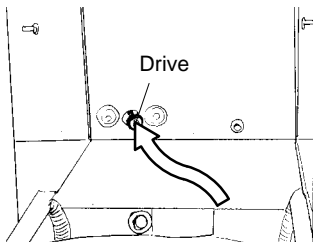

- ☞ Insert the storage container in the drive at the rear.
- If the storage container cannot be fitted, turn the shaft of the screw conveyor inside the container slightly until it fits.

Close the front panel / cover

- ☞ Swing the front panel upwards and slowly lower it.

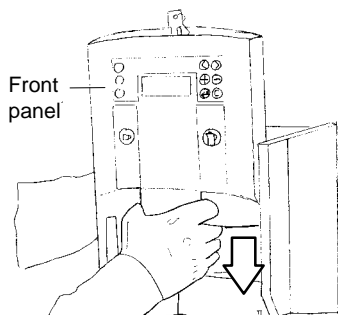

- ☞ Close and lock the cover of the storage container.

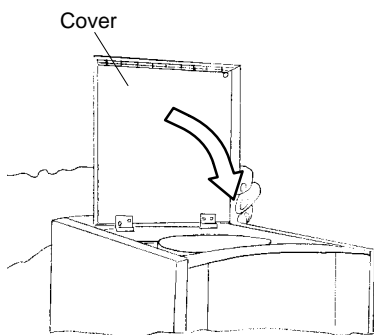

4.3 Cleaning the housing



Cleaning the surface of the unit (exterior)

- ☞ All surfaces (plastic parts, painted enclosures, stainless steel surfaces) should be wiped with a damp cloth.
- ☞ Dry the cleaned surfaces.
- ☞ Polish the stainless steel surfaces with a thin film of care agent for stainless steel.

Cleaning the drip tray and grid

- ☞ Prise the grid out with a teaspoon, for example, and remove it.
- ☞ Clean the drip tray and grid with a washing-up brush, fat-dissolving detergent and warm water. Wipe with a damp cloth.
- ☞ Thoroughly dry all parts.
- ☞ Place the grid in the drip tray.

Cleaning the inside of the front panel

- ☞ Remove sugar residues with a brush and damp cloth.

5. Troubleshooting

If faults develop in the unit, try to locate the cause of the fault with the aid of the following table first of all:

Fault	Possible cause	Remedy
Sugar is not dispensed.	Mains connector not plugged in. Appliance switch switched off. Storage container is empty. Metering screw in storage container is blocked.	Plug in mains connector. Switch on appliance switch. Fill storage container with medium-fine sugar. Remove storage container and clean it to eliminate impurities.
A grinding sound is heard when sugar is dispensed.	The sugar in the storage container is too coarse.	Empty the storage container, clean it and ensure it is refilled with medium-fine sugar.



If the fault cannot be remedied

- Switch off the unit via the appliance switch and unplug the mains connector.
- Close the water feed valve.
- Do not open the housing.
- Contact the customer service engineer and report the model, machine number and year of construction.

6. Technical data

VIVA Sugar Dispenser	Article No. 198862
Delivery Storage container capacity	Free-flow Approx. 2 kg medium-fine sugar
Dimensions: Width x Height x Depth	240 x 600 x 540 mm
Net weight	Approx. 20 kg
Electrical connection Total connected load Fuse	230 V AC 1N 50/60 Hz 200 W 16 A
Ambient temperature during operation	5° to 35° C
Noise level	Less than 70dB (A)

Subject to change without notice!

7. Installation and connection



- The customer service engineer is responsible for installation, connection, starting up for the first time and for instructing personnel on how to operate the unit.
- The customer is responsible for ensuring that the connections are installed up to one metre from the installation point.

7.1 Installation

- The VIVA Sugar Dispenser must not be installed in rooms in which water hoses or high-pressure cleaners are used!
- Der A distance of at least 4 cm must be maintained between the unit and the wall (so that air can circulate). Sufficient space must be allowed so that sugar can be filled from above (see diagrams below).
- The unit must not be installed near sources of heat. Ensure that a sufficient distance is maintained (otherwise the housing panels will become warped by heat).
- Vents must not be obstructed!
- The unit must be installed on a robust surface so that it is horizontal. Any unevenness can be compensated with the screw feet.

Supply connections

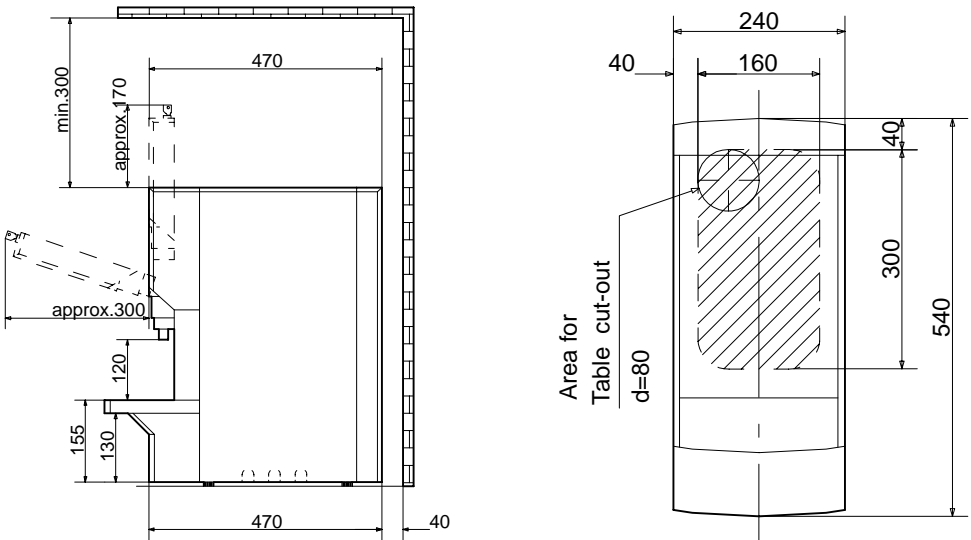

7.2 Electrical connection



- The unit may only be connected to the electricity supply by a qualified electrician
 - in accordance with the applicable regulations VDE 0100
 - and in accordance with the regulations of the relevant public utility.
 - The flexible mains power cord must at least be enclosed in a rubber hose line of type H 05 RN-F (as per VDE regulations).
 - The unit must be integrated into the equipotential bonding system.
 - Note the data on the rating plate when connecting to the power supply!
- ☞ Plug the mains connector into a correctly installed and earthed socket outlet (230 Volt).
- The mains connector must be readily accessible.

8. Maintenance / Customer service / Rating plate

Maintenance

- Installation, maintenance and repair work may only be carried out by authorized customer service engineers.
- Only original accessories and original spare parts should be used!
- Conclude a service agreement with your customer service engineer. He will be glad to explain the advantages of such a service agreement to you.

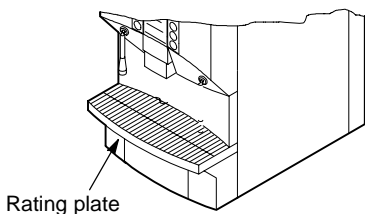

Entering the data on the rating plate

- ☞ Enter the data from the rating plate in these Operating Instructions.

Type No.: _____

Serial No.: _____

Year built: _____

Please specify these data whenever you require service work for your VIVA Sugar Dispenser. This will speed up processing of your enquiry.

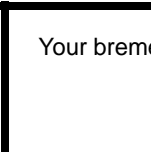

Your bremer partner



bremer Kaffeemaschinen AG
Lindenweg 36-42
D-97999 Igersheim
Phone +49 7931 992 297
Fax +49 7931 517 00
www.bremer-kaffee.de

bremer
COFFEEMACHINES